

1.2A LED DRIVER with INTERNAL SWITCH

Features

- Simple low parts count
- Wide input voltage range: 4V to 40V
- 1.2A output current
- Single pin on/off
- Brightness control by using DC voltage
- Brightness control by PWM signals
- Typical 5% output current accuracy
- High efficiency (up to 97%)
- Up to 1MHz switching frequency
- Adjustable Constant LED Current
- Soft-start
- 40V transient capability

Description

The SC2008 is a continuous conduction mode inductive step-down converter, designed for driving single or multiple series connected LEDs efficiently from a voltage source higher than the total LED chain voltage. The device operates from an input supply between 4V and 40V and provides an externally adjustable output current up to 1.2A. Depending upon the supply voltage and external components, the SC2008 can provide up to 30watts of output power.

The SC2008 includes the power switch and a high-side output current sensing circuit. Output current can be programmed by an external resistor. A dedicated ADJ input accepts either a DC voltage or a wide range of pulsed dimming to adjust the output current above or below the set value. Applying a voltage of 0.2V or lower to the ADJ pin turns the output off and switches the device into a low current standby mode.

The SC2008 is available in TSOT-23-5 packages.

Applications

- Low voltage halogen replacement LEDs
- Automotive lighting
- Low voltage industrial lighting
- LED back-up lighting
- Illuminated signs
- High power LED lighting

Package Information

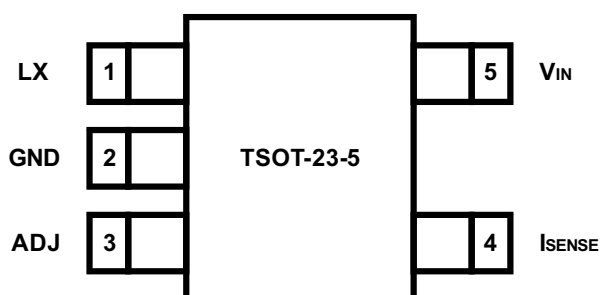

Top View

TSOT-23-5

Ordering Information

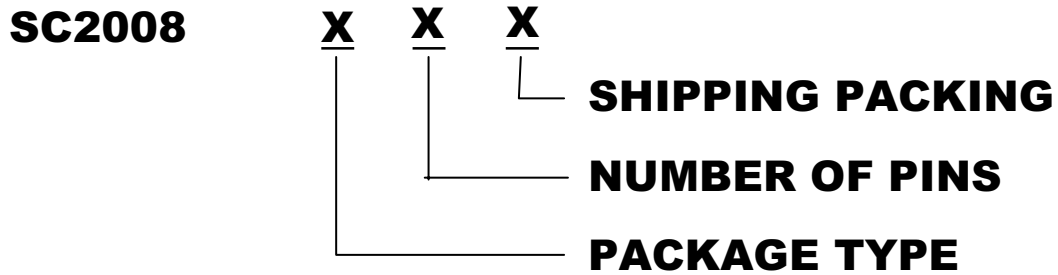

Package Type	Number of pins
A : SOT-23	B : 5

Block Diagram

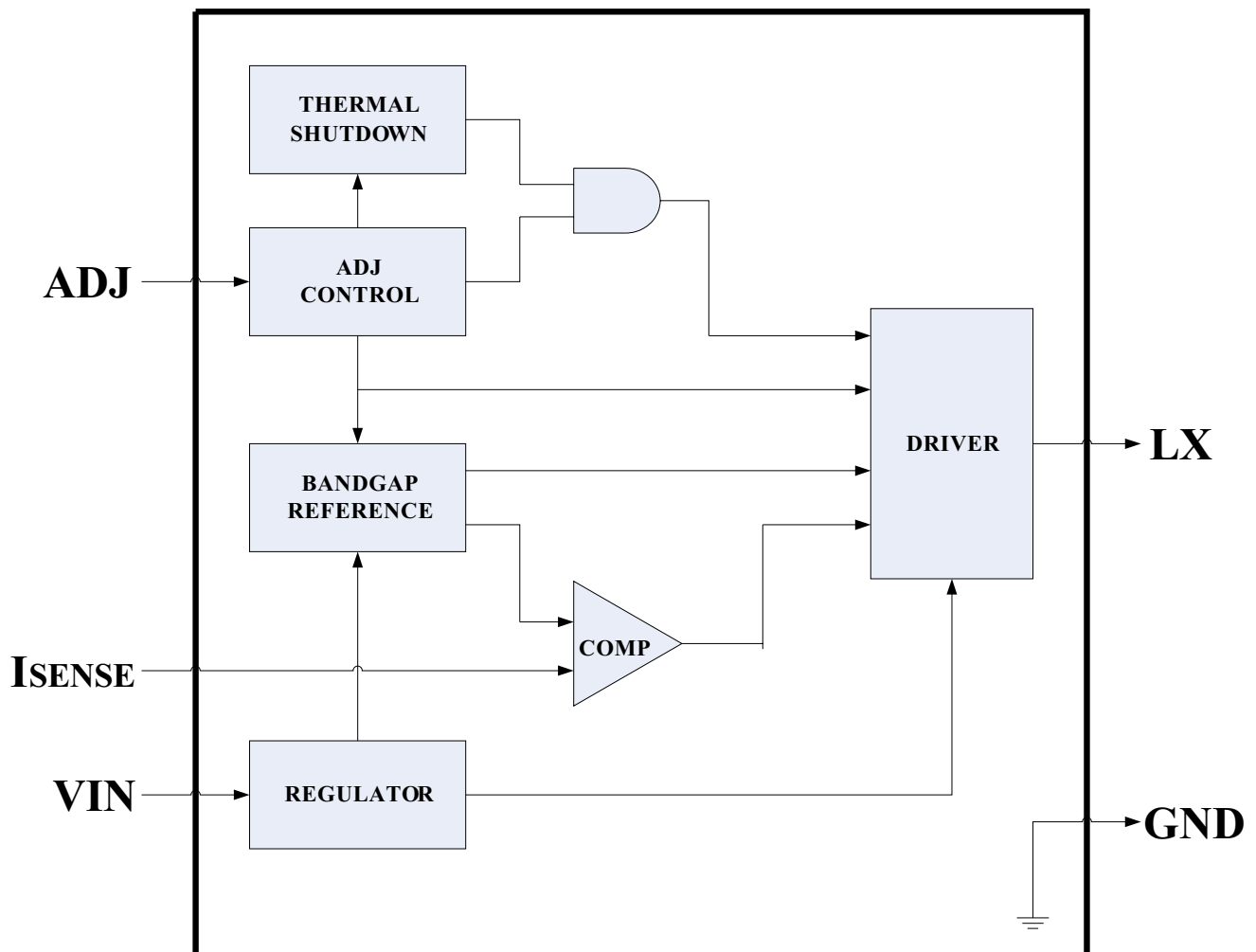

Typical Application

SC2008 DC 12V Input Application

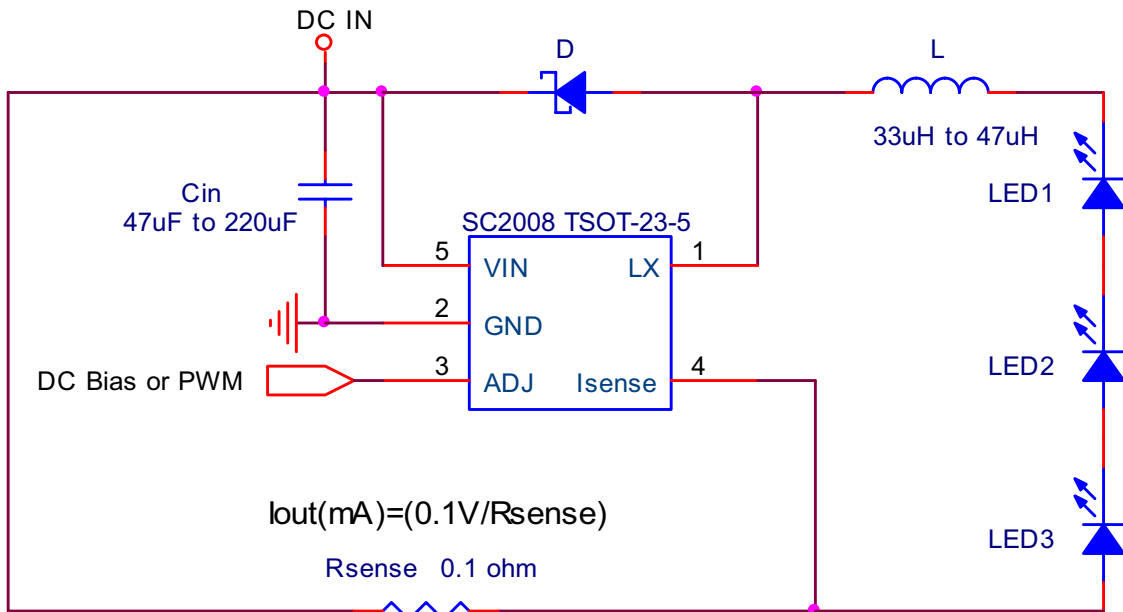

SC2008 AC 12V Input Application

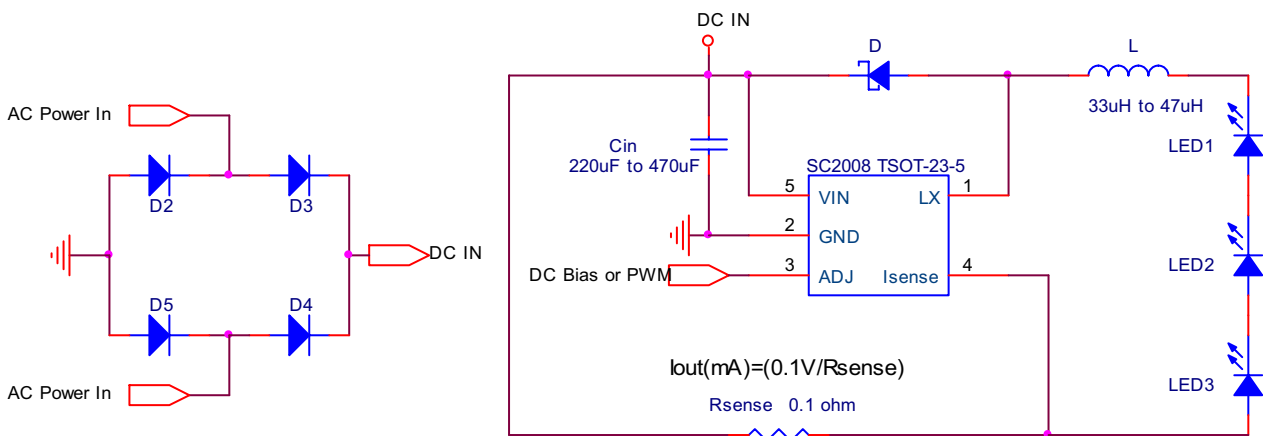

Pin Description

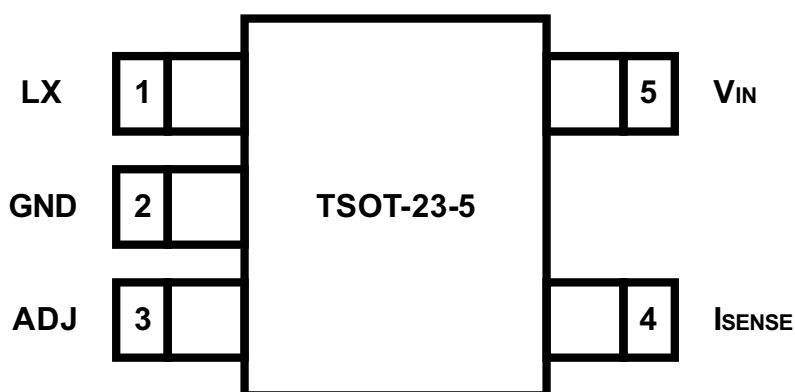

PIN No.	PIN NAME	FUNCTION
1	LX	The drain of the internal N-MOSFET switch.
2	GND	Signal and power ground.
3	ADJ	<p>Multi-function On/Off and brightness control pin:</p> <ul style="list-style-type: none"> “Floating” for normal operation. <p>The normal average output current $I_{OUT(nom)} = \frac{0.1V}{R_{SENSE}}$</p> <p>“DC below 0.2V” to enter stand by mode.</p> <ul style="list-style-type: none"> “DC between 0.3V and 2.5V” to adjust output current from 25% to 200% of $I_{OUT(nom)}$. “Low frequency lower than 500Hz & High frequency higher than 10KHz” to adjust output current. Increasing soft-start time by connecting a capacitor from this pin to GND.
4	I_{SENSE}	<p>Connect resistor R_S from this pin to V_{IN} to define nominal average output current.</p> $I_{OUT(nom)} = \frac{0.1V}{R_{SENSE}}$ <p>(Note: $I_{OUT} = 1.25A$、$R_{SENSE(min)} = 0.08\Omega$ with ADJ pin floating)</p>
5	V_{IN}	Input voltage (4V~40V).

Maximum Ratings

CHARACTERISTIC	SYMBOL	RATING	UNIT
Supply Voltage	V_{IN}	-0.3 ~ 40	V
Current sense input (Respect to VIN)	$V_{I_{SENSE}}$	+0.3 ~ -0.3	V
LX output voltage	V_{LX}	-0.3 ~ 40	V
Adjust pin input voltage	V_{ADJ}	- 0.3 ~ 6	V
Switch output current	I_{LX}	1.2	A
Power dissipation	P_D	1000	mW
Operating temperature	T_{OP}	-40 to 125	°C
Storage temperature	T_{STG}	-55 to 150	°C
Junction temperature	T_J	150	°C

Note:

The maximum power dissipation is $P_{D_{MAX}} = \frac{(T_{J_{MAX}} - T_A)}{\theta_{JA}}$

Electrical Characteristics ($V_{IN} = 12V$, $T_A = 25^\circ C$ unless otherwise stated)

CHARACTERISTIC	SYMBOL	CONDITION	MIN.	TYP.	MAX.	UNIT
Input voltage	V_{IN}		4		40	V
Supply current of stand by mode	I_{STAND}	ADJ pin grounded		25	40	μA
Supply current of switching mode	I_{SWITCH}	ADJ pin floating		300	800	μA
Mean current sense threshold voltage	V_{ISENSE}	Measured on I_{SENSE} pin with respect to V_{IN} (ADJ floating)	95	100	105	mV
Sense threshold hysteresis	$V_{SENSEHYS}$			$\pm 15\%$		
ISENSE pin input current	I_{SENSE}	$V_{IN} - V_{ISENSE} = 0.1$		1.5	10	μA
Internal reference voltage	V_{ADJ}		-3%	1.25	+3%	
External control voltage range on ADJ pin for DC brightness control	V_{ADJ}		0.3		2.5	V
DC voltage on ADJ pin to switch device from switch mode to stand by mode	V_{STAND}	V_{ADJ} falling	0.15	0.2	0.25	V
DC voltage on ADJ pin to switch device from stand by mode to switch mode	V_{SWITCH}	V_{ADJ} rising	0.2	0.25	0.3	V
Resistance between ADJ pin and V_{REF}	R_{ADJ}	$0 < V_{ADJ} < V_{REF}$ $V_{ADJ} > V_{REF} + 100mV$	165 16		333 33	K Ω
LX switch current	I_{LX}				1.2	A
LX switch on resistance	R_{LX}	$I_{LX} = 1A$		0.33		Ω
LX switch leakage current	I_{LEAK}				3	μA
Duty cycle of PWM dimming applied to pin ADJ during low frequency	D_{LF}	PWM frequency $< 500HZ$ and its amplitude = V_{REF}	0.01		1	
Duty cycle of PWM dimming applied to pin ADJ during high frequency	D_{HF}	PWM frequency $> 10KHZ$ and its amplitude = V_{REF}	0.24		1	
Operating frequency	F_{OP}	ADJ pin floating, $L = 33\mu H$, $I_{LX} = 1A$, Driving 1 LED		280		KHz
Minmum switch on time	T_{ON_MIN}	LX switch on		240		ns
Minmum switch off time	T_{OFF_MIN}	LX switch off		200		ns
Recommanded minimum switch on time	T_{ON}	LX switch on		800		ns
Recommended maximum operating frequency	F_{MAX}				1	MHz
Recommended duty cycle range of output switch at Fmax	D_{MAX}		0.3		0.7	
Thermal shutdown threshold	T_{SD}			165		$^\circ C$
Thermal shutdown hysteresis	T_{SDHYS}			25		$^\circ C$

Operation Description

The device, in conjunction with the inductor (L1) and current sense resistor (R_{SENSE}), forms a self oscillating continuous mode buck converter.

When input voltage V_{IN} is first applied, the initial current in L1 and R_{SENSE} is zero and there is no output from the current sense circuit. Under this condition, the output of I_{SENSE} comparator is high. This turns on an internal switch and switches the LX pin low, causing current to flow from V_{IN} to ground, via R_{SENSE} , L1 and the LED(s). The current rises at a rate determined by V_{IN} and L1 to produce a voltage ramp (V_{ISENSE}) across R_{SENSE} . When $(V_{IN} - V_{ISENSE}) > 115mV$, the output of I_{SENSE} comparator switches low and the switch turns off. The current flowing on the R_{SENSE} decreases at another rate. When $(V_{IN} - V_{ISENSE}) < 85mV$, the switch turns on again and the mean current on the LED(s) is determined by

$$\frac{\left(\frac{85mV + 115mV}{2}\right)}{R_{SENSE}} = \frac{100mV}{R_{SENSE}}$$

The high-side current sensing scheme and on board current setting circuitry minimize the number of external components while delivering LED(s) current with $\pm 5\%$ accuracy, using a 1% sense resistor.

The SC2008 allow dimming with a PWM signal at the ADJ input. A logic level below 0.3V at ADJ forces SC2008 to turn off the LED and the logic level at ADJ must be at least 2.5V to turn on the full LED current. The frequencies of PWM dimming ranges from lower than 100Hz or more than 20 KHz.

The ADJ pin can be driven by an external DC voltage (V_{ADJ}) to adjust the output current to a value below the nominal average value defined by R_{SENSE} . The DC

voltage is valid from 0.3V to 2.5V. When the dc voltage is higher than 2.5V, the output current keeps constant. The LED(s) current also can be adjusted by a resistor connected to the ADJ pin. An internal pull-up resistor is connected to a 5V internal regulator. The voltage of ADJ pin is divided by the internal and external resistor. The ADJ pin is pulled up to the internal regulator (5V). It can be floated at normal working. When a voltage applied to ADJ falls below the threshold (0.2V nom.), the output switch is turned off. The internal regulator and voltage reference remain powered during shutdown to provide the reference for the shutdown is nominally $20 \mu A$ and switch leakage is below $3 \mu A$.

Additionally, to ensure the reliability, the SC2008 is built with a thermal shutdown (TSD) protection and a thermal pad. The TSD protects the IC from over temperature ($165^{\circ}C$). Also the thermal pad enhances power dissipation. As a result, the SC2008 can handle a large amount of current safely.

Typical Performance Characteristic

Actual operating waveform [$V_{IN}=6.0V$ $R_S=0.1\Omega$ $L=47\mu H$]

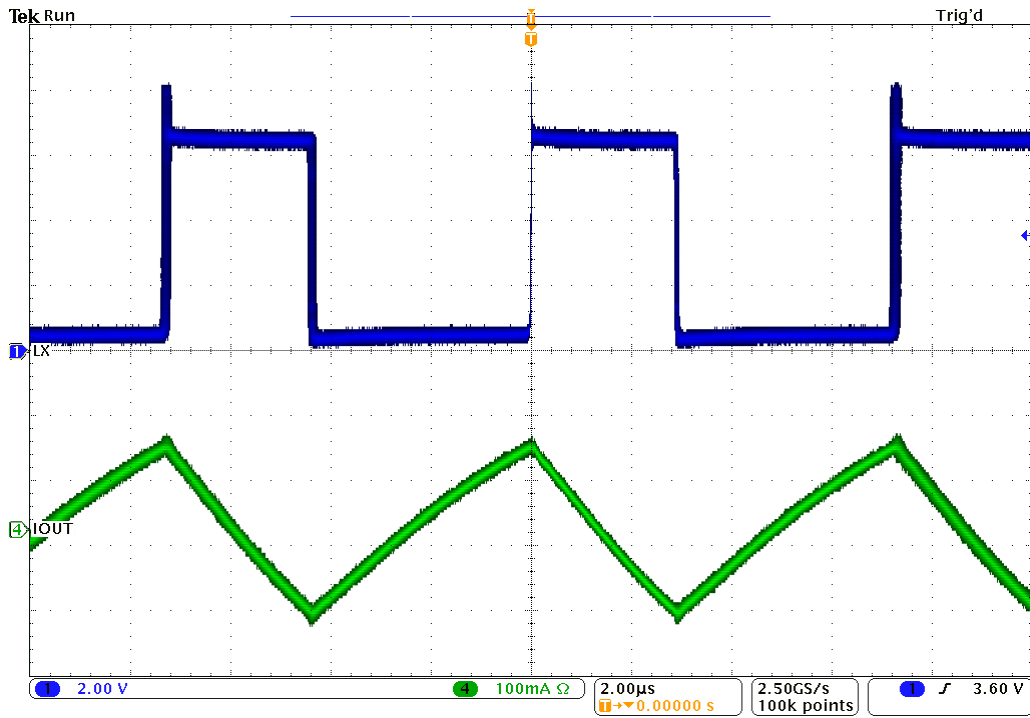

29 Sep 2009
14:04:22

Actual operating waveform [$V_{IN}=12V$ $R_S=0.1\Omega$ $L=47\mu H$]

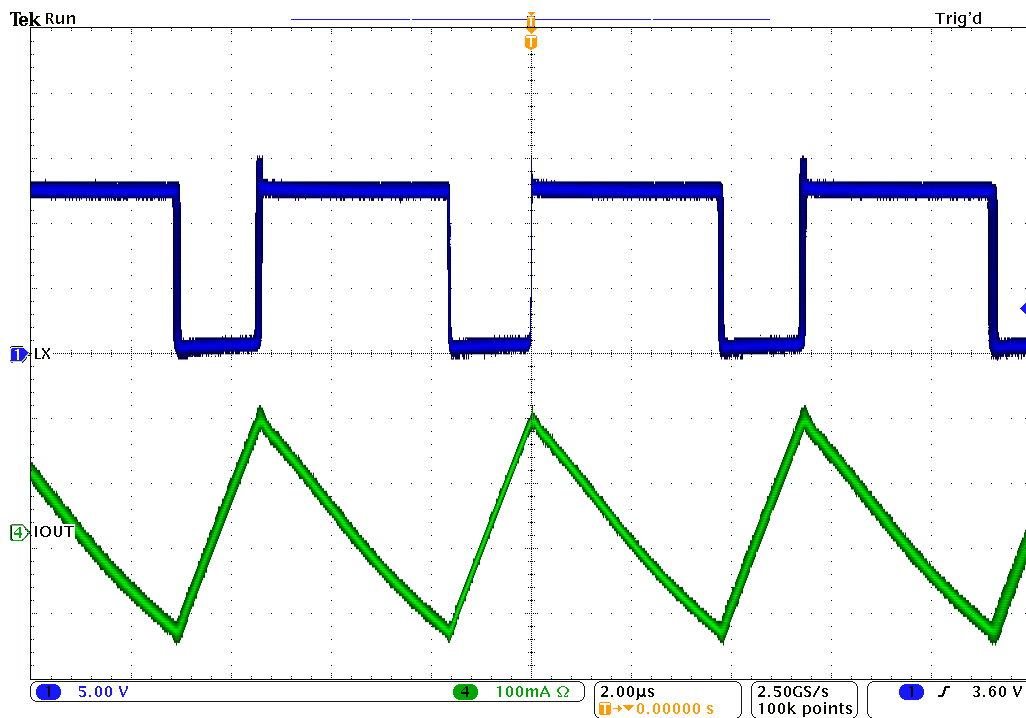

29 Sep 2009
14:04:33

Actual operating waveform [$V_{IN}=24V$ $R_S=0.1\Omega$ $L=47\mu H$]

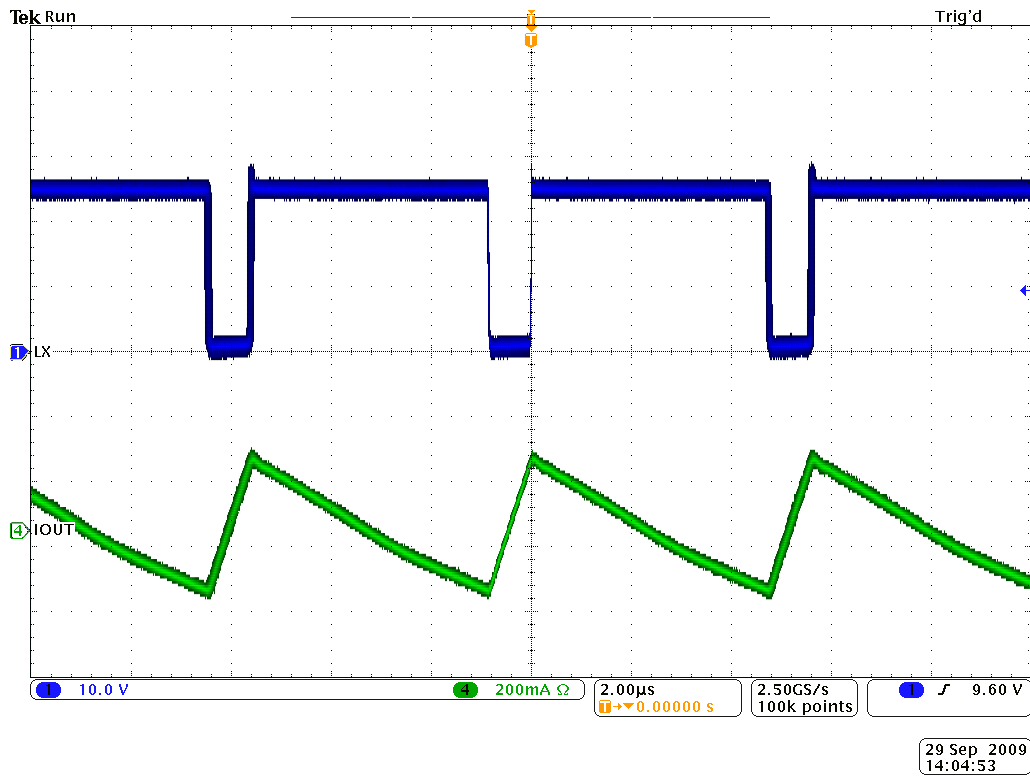

Actual operating waveform [$V_{IN}=32V$ $R_S=0.1\Omega$ $L=47\mu H$]

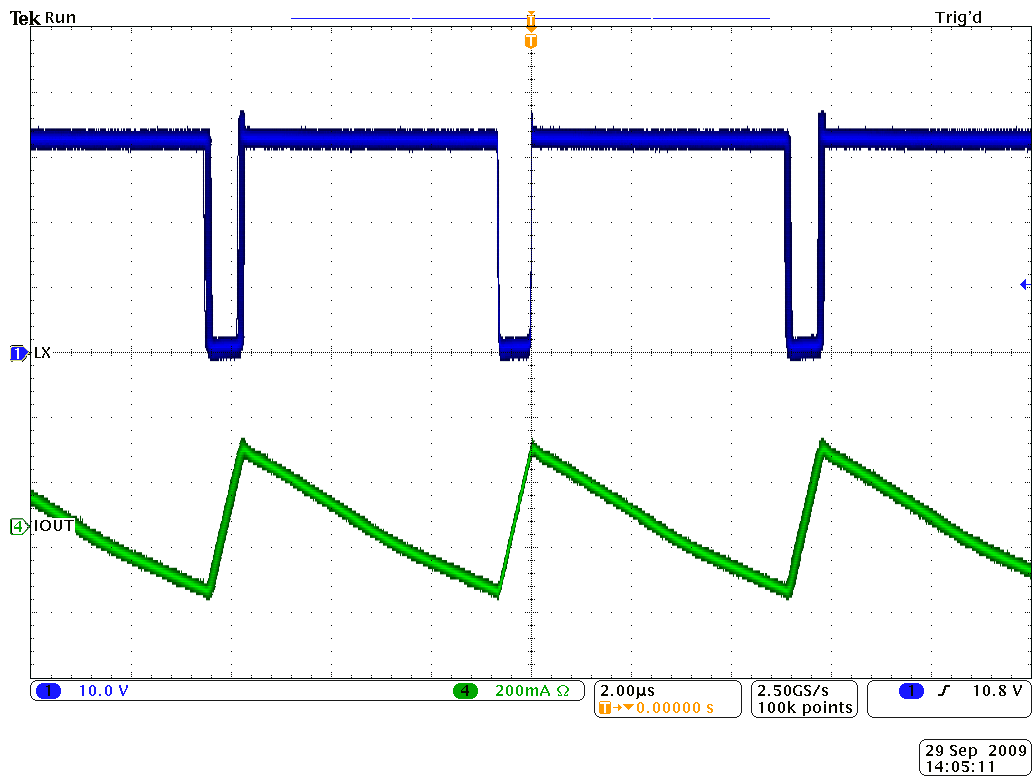

Typical Performance Characteristic

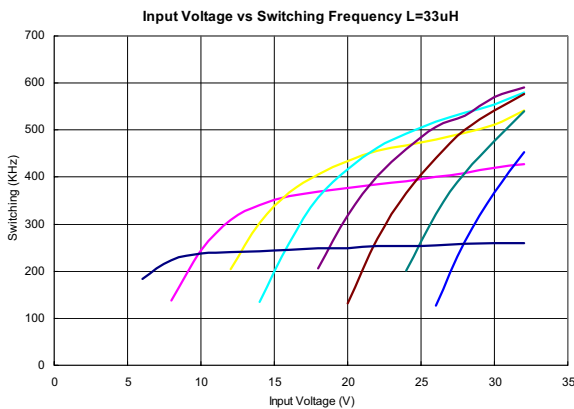
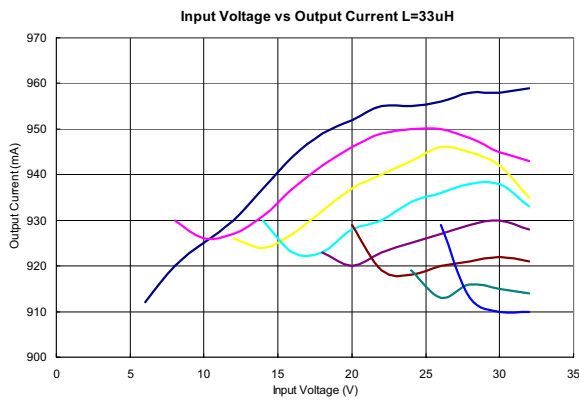
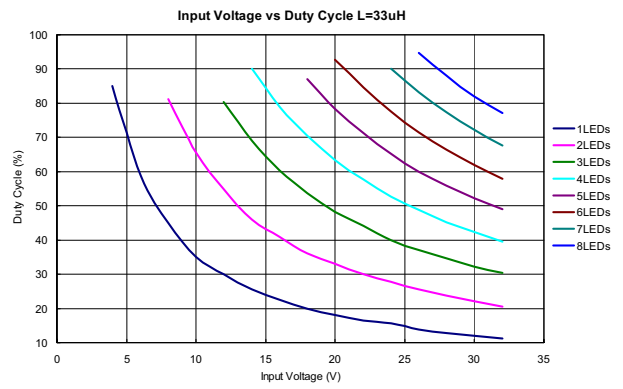
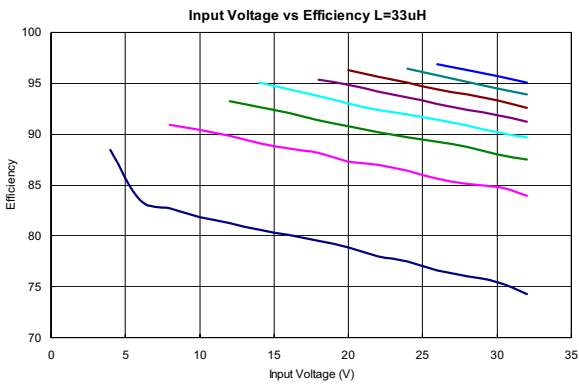

Typical Performance Characteristic

Input Voltage vs Efficiency L=47uH

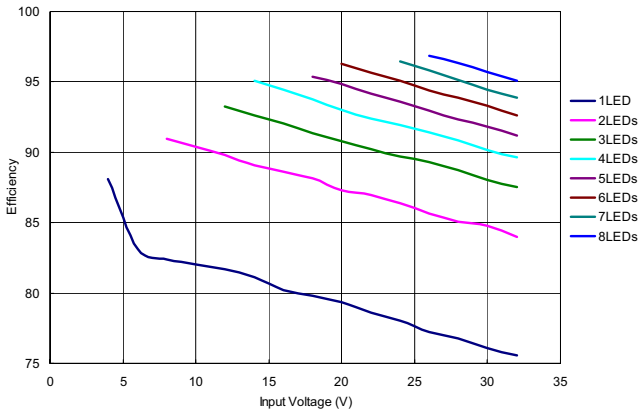

Input Voltage vs Duty Cycle L=47uH

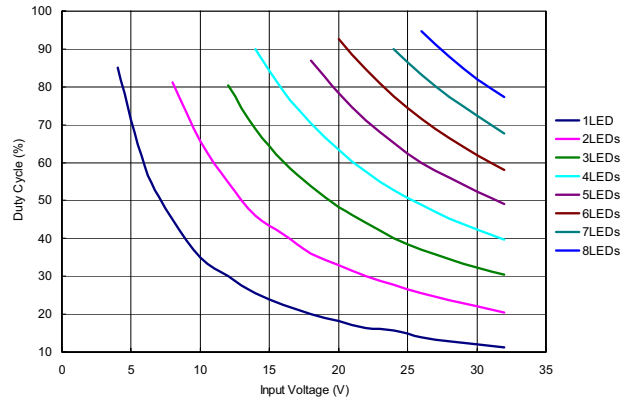

Input Voltage vs Output Current L=47uH

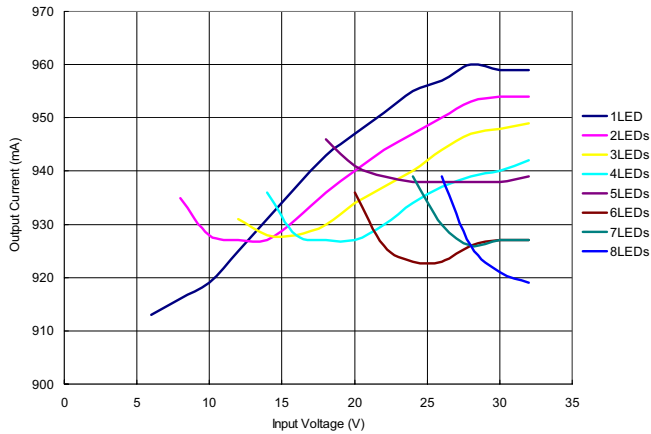

Input Voltage vs Switching Frequency L=47uH

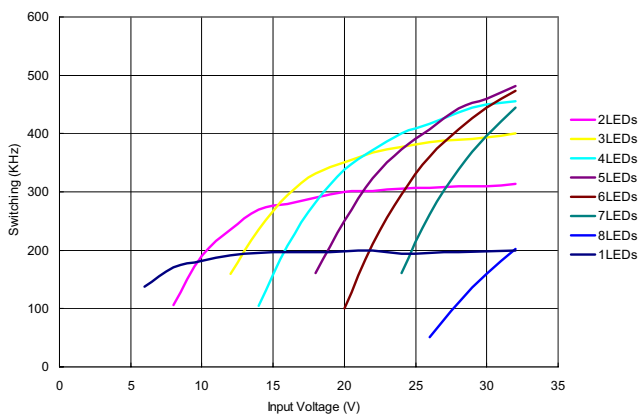

Typical Performance Characteristic

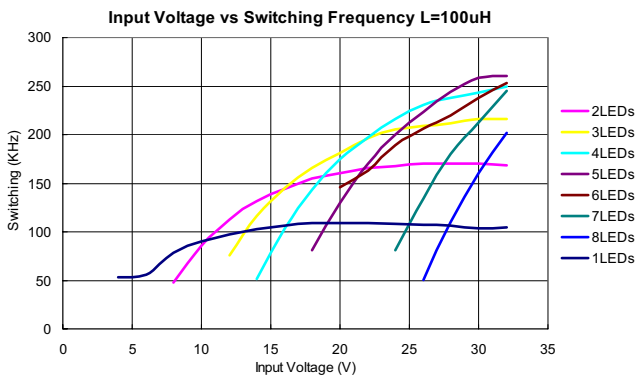
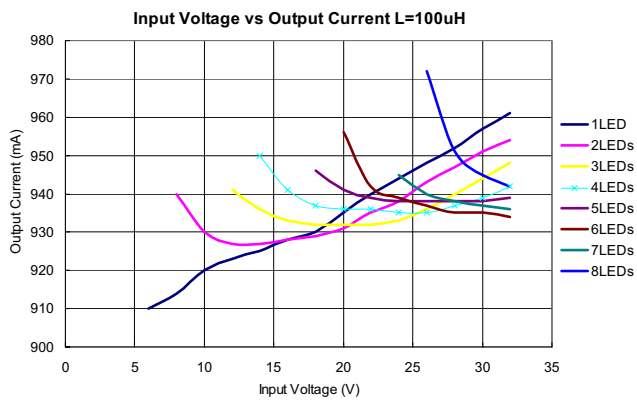
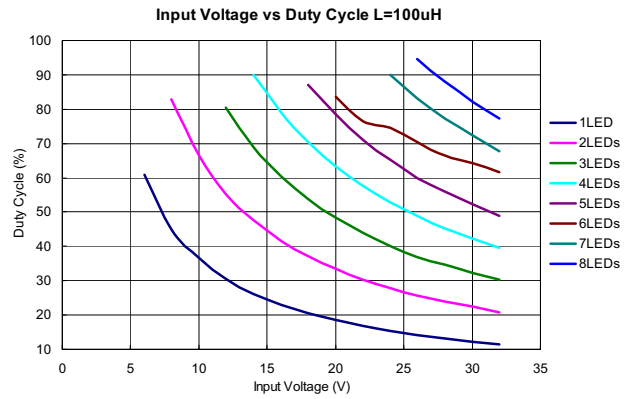
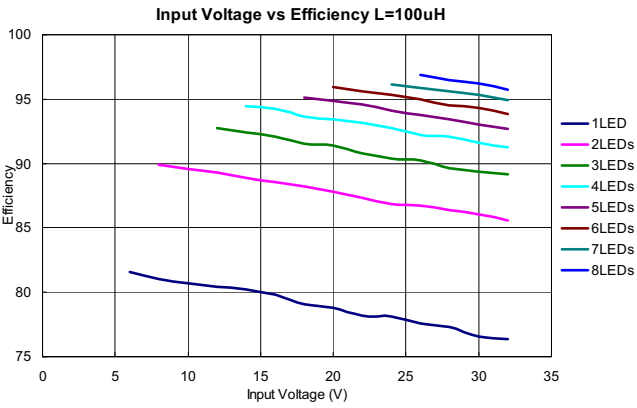

Typical Performance Characteristic

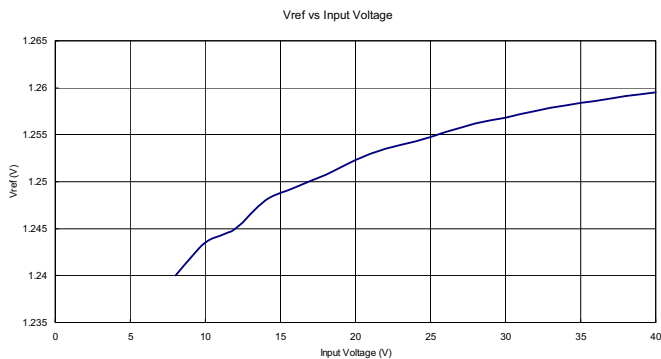
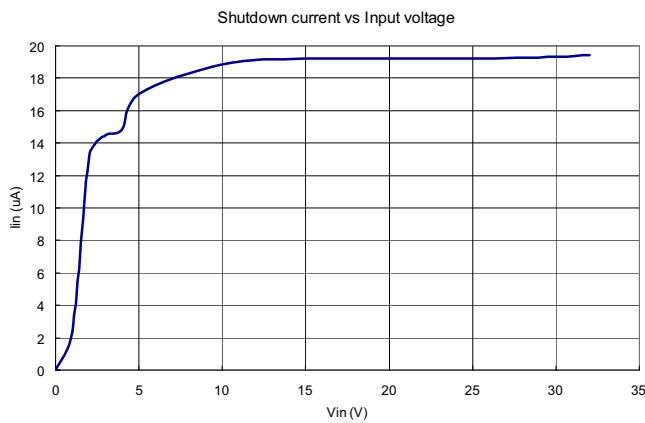
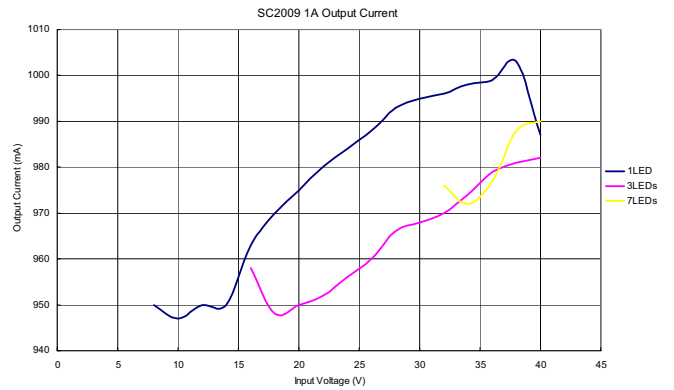
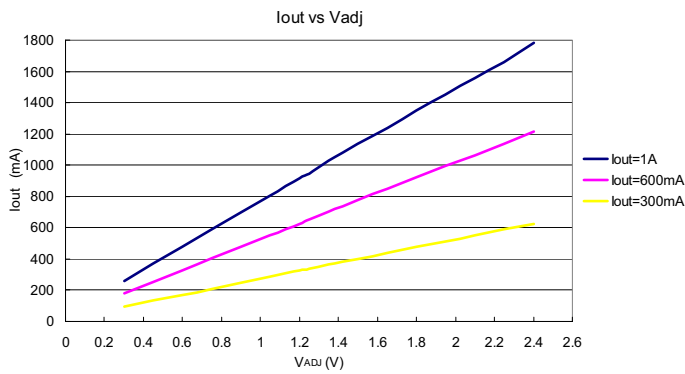

Application notes

Setting nominal average output current with external resistors R_{SENSE} .

The nominal average output current in the LED(s) is determined by the value of external resistor R_{SENSE} ,

That is connected between V_{IN} and I_{SENSE} . It is given by the following formula.

$$I_{OUT(nom)}(A) = \frac{0.1V}{R_{SENSE}}, \quad R_{SENSE} \geq 0.08\Omega$$

For example: The nominal output current is 500mA when R_{SENSE} is 0.2 Ω .

$R_{SENSE} (\Omega)$	$I_{OUT(nom)} (mA)$
0.1	1000
0.13	760
0.3	333

The above values assume that ADJ pin is floating and at a voltage of $V_{ref} = 1.25V$. $R_{SENSE} = 0.08\Omega$ is the minimum allowed value of sense resistor under conditions to maintain switch current below the specified maximum value.

Adjust the output current by external DC voltage.

According to the above section, the output average current is equal to $I_{OUT(nom)}$ when ping ADJ is floating.

However, the output current could be adjusted by applying external voltage to the ADJ pin.

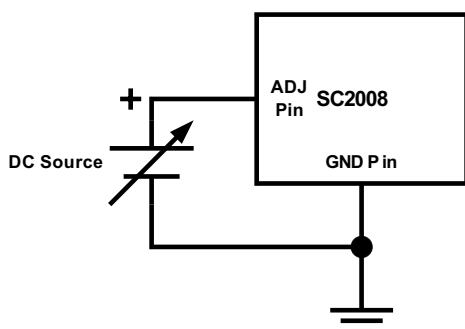

The formula is as below:

$$I_{OUT(DC)}(mA) = I_{OUT(NOM)} \times \left(\frac{V_{ADJ}}{1.25} \right) = \left(\frac{100mV}{R_{SENSE}} \right) \times \left(\frac{V_{ADJ}}{1.25} \right)$$

,for $RS \geq 0.08\Omega$ and $2.5 > V_{ADJ} > 0.3$

For example:

$$R_{SENSE} = 0.2, \quad V_{ADJ} = 0.625V$$

The output current $I_{OUT(DC)}$ comes out to be 250mA.

However, the maximum output current is limited by 1.2A.

Adjust the output current by external PWM voltage.

As the same reason, the output average current is equal to $I_{OUT(NOM)}$ when ADJ pin is floating. And the output current of SC2008 could be adjusted by applying external PWM dimming voltage to the ADJ pin.

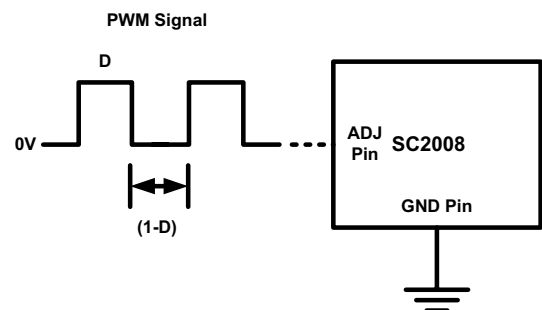

Assume that the PWM signal is a square wave with a high level 1.25V and its duty is equal to D

The formula is as below:

$$I_{OUT(DC)}(mA) = I_{OUT(nom)} \times D = \left(\frac{100mV}{R_{SENSE}} \right) \times D$$

, for $RS \geq 0.08\Omega$ and Duty Cycle ($D < 1$)

For example: When $RS = 0.2$, $D = 0.5$

The output current $I_{OUT(DC)}$ comes out to be 250mA.

However, the D should be above 0.24 therefore the $V_{dim(AVG)}$ is higher than $1.25 \times 0.24 = 0.3V$. And the SC2008 would not be turned off.

Using high voltage or AC input

When DC input voltage is above 32V, we recommend that increase input capacitor (C_{IN}) from 47 μ F to 220 μ F.

This would reduce the inrush voltage and avoid the SC2008 to be cracked.

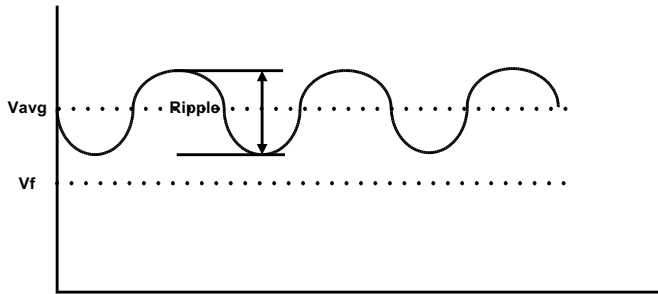

In AC input, the figure above shows the V_{IN} waveform, that is after the Bridge Rectifiers. In some cases, the V_{IN} would be lower than LED(s) V_f according by the input capacitor, how many LED(s) do you use and the characteristic of the LED. That would result the $I_{OUT(NOM)}$ is lower than you might expect. In order to avoid this situation, you may increase the input capacitance to reduce the ripple or choose the proper numbers of LED(s).

Shutdown mode

SC2008 ADJ pin voltage is under 0.2V for more than approximately 100 μ s, SC2008 will turn off the output and SC2008 into standby mode, supply current will fall to 25 μ A.

Note that ADJ pin isn't a logic input, Taking ADJ pin to a voltage above V_{ref} will increase output current above the 100% nominal average value.

Soft-Start

SC2008 has inbuilt soft-start function due to delay through PWM filter. An external capacitor from ADJ pin to ground will provide additional soft-start delay time, by increasing the time taken for the voltage on this pin to rise to turn on threshold and slowing down the rate

of rise of the control voltage at input of the comparator. With no external capacitor, the time taken for the output to reach 90% of its final value is approximately 1.5mS. Adding capacitor increase this delay by $0.46 \times C(nF)$. The graph below shows the variation of soft-start time for different values of capacitor.

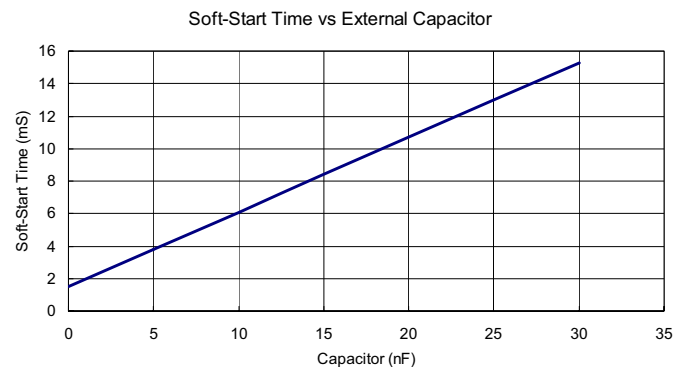

Actual operating waveform [$V_{IN}=24V$ $R_S=0.1\Omega$ $L=47\mu H$, 0nF on ADJ pin]

Soft-start waveforms. Input voltage (Ch1), LX voltage (Ch2) and Output current (Ch4)

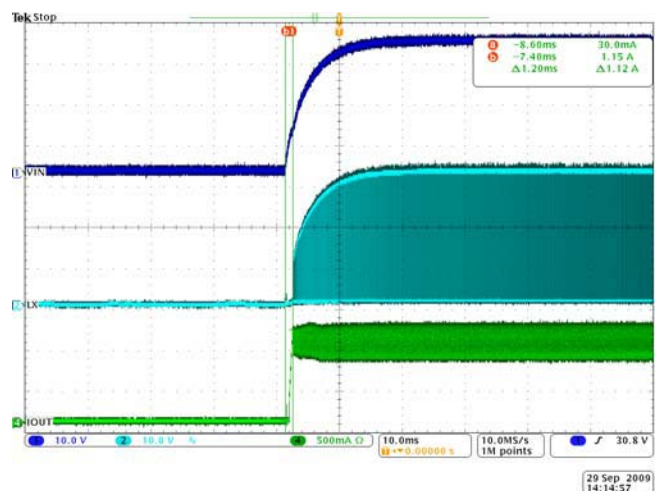

Actual operating waveform [$V_{IN}=24V$ $R_S=0.1\Omega$

$L=47\mu H$, $100nF$ on ADJ pin]

Soft-start waveforms. Input voltage (Ch1), LX voltage (Ch2) and Output current (Ch4)

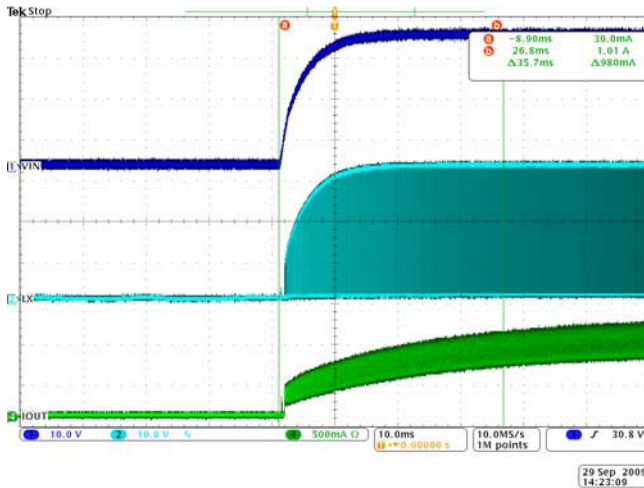

LED(s) open circuit protection

If the connection to LED(s) is open circuited, the inductor is isolated from LX pin of SC2009, so SC2008 will not be damaged.

Inductor selection

Recommended inductor values for SC2008 are in the range during 33uH to 100uH. Higher values of inductance are recommended at higher input voltage in order to minimize errors due to switching delays, which result in increased ripple and lower efficiency. Higher values of inductor also result in smaller change in output current over input voltage range. The inductor should be mounted as close to SC2008 as possible with low resistance connections to LX and V_{IN} pins.

The coil should have a saturation current higher than the peak output current and a continuous current rating above the required mean output current.

Part no.	L (uH)	DCR (Ω)	I_{SAT} (A)
PIC124-330	33	0.097	2.7
PIC124-470	47	0.15	1.9
PIC124-101	100	0.308	1.2

The inductor value should be chosen to maintain operating duty cycle and switch times within the specified limits over input voltage and load current range.

The following equations can be used as a guide.

LX Switch ON time:

$$T_{ON} = \frac{L \times \Delta I}{V_{IN} - V_{LED} - I_{avg} \times (R_{SENSE} + r_L + R_{LX})}$$

$$T_{ON(min)} > 240nS$$

LX Switch OFF time:

$$T_{OFF} = \frac{L \times \Delta I}{V_{LED} + V_D + I_{avg} \times (R_{SENSE} + r_L)}$$

$$T_{ON(min)} > 200nS$$

Where:

L is the inductor inductance (H)

r_L is the inductor resistance (Ω)

R_{SENSE} is the current sense resistance

I_{avg} is the required LED(s) current (A)

ΔI is the inductor peak-peak ripple current (A)

V_{IN} is input voltage (V)

V_{LED} is the total LED(s) forward voltage (V)

R_{LX} is the switch resistance (Ω)

V_D is the diode forward voltage at the required load current (V)

Optimum performance will be achieved by setting duty cycle (D) close to 0.5 at the nominal input voltage. It assists to equalize undershoot and overshoot and improve temperature stability of SC2008 output current.

Diode selection

For better efficiency and performance, the rectifier (Diode) should be a fast capacitance Schottky diode with low reverse leakage at the maximum operating voltage and temperature.

Schottky diode also provides better efficiency than silicon diode, due to a combination of lower forward

voltage and reduced recovery time.

It's a point to select components with peak current rating above peak inductor current and a continuous current rating higher than the maximum output load current. It's too important to consider the reverse leakage of diode when operating above 85°C. Excess leakage will increase power dissipation in SC2008 and if close to the load may create a thermal runaway condition.

The higher forward voltage and overshoot due to reverse recovery time in silicon diode will increase peak voltage on LX output. If silicon diode is used, should be taken to ensure that total voltage appearing on LX pin including supply ripple, doesn't exceed the specified maximum value.

Capacitor selection

Low ESR capacitor should be used for input decoupling, as the ESR of capacitor appears in series with power supply source impedance and lower overall efficiency. The capacitor has to supply the relatively high peak current to inductor and smooth the current ripple on the input supply. A minimum value of 22uF is acceptable if input source is close to SC2008, but higher values will improve performance at lower input voltage, when input source impedance is high. The input capacitor should be placed as close as possible to SC2008.

For maximum stability over voltage and temperature, the capacitors with X7R, X5R or better dielectric are recommended. Y5V capacitor is not suitable for decoupling in the application and should not be used.

Reducing output ripple

Peak-Peak ripple current in LED(s) can be reduced, if required, by shunting a capacitor C-LED LED(s) as shown below.

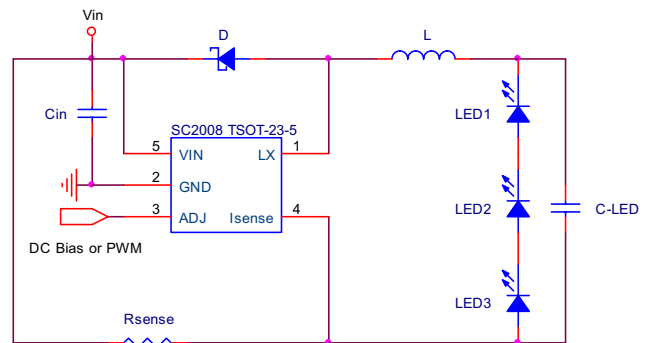

1uF C-LED will reduce input supply current. Proportionally lower ripple can be achieved with higher capacitor values. The capacitor will affect operating frequency or efficiency, but it will increase start up time, by reducing the rate of rise of LED voltage. By adding the capacitor the current waveform across LED(s) changes from a triangular ramp to a more sinusoidal version without altering the mean current value.

Thermal considerations

When using the module at high ambient temperatures, or driving heavy current, must be taken to avoid exceeding IC package power dissipation limit. The figure below provides details for power derating. This assumes the module to be mounted on 20mm² PCB with 1oz copper standing in air.

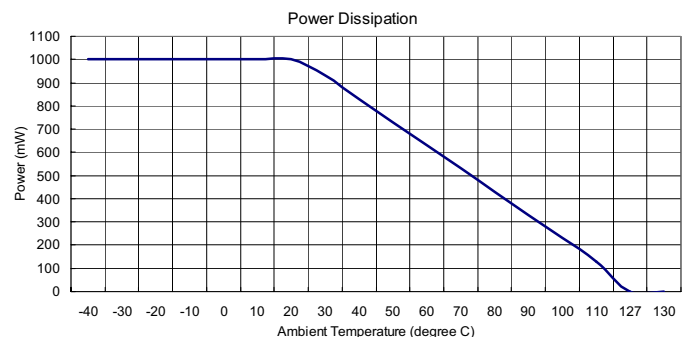

Thermal compensation of output current

High luminance LED(s) needs to be supplied with a temperature compensated current in order to maintain stable and reliable operation at all driving conditions. LED(s) are usually mounted remotely from the module. Base on the reason, the temperature factor of internal circuit for SC2008 has been optimized to minimize the charge in output current when no compensation is employed.

Layout guides

SC2008 LX pin

LX pin of the module is a fast switching point, PCB trace should be kept as short as possible. To minimize GND, GND pin of the module should be soldered directly to the GND plane.

Inductor and decoupling capacitor and current sense resistor

It's important to mount inductor and input capacitor as close to SC2008 pins as possible to minimize parasitic resistance and inductance, which will increase efficiency. It's also important to minimize trace resistance in series with current sense resistor R_{SENSE} .

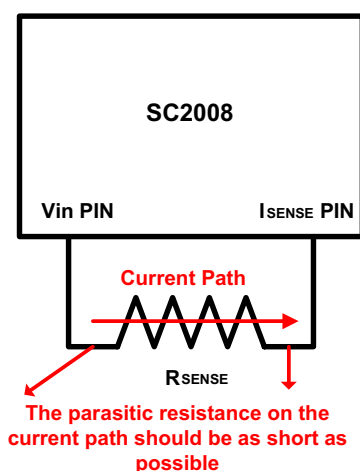

It's best to connect V_{IN} directly to one end of R_{SENSE} and I_{SENSE} directly to the opposite end of R_{SENSE} with no other current flowing in these traces. This is

important that cathode current of Schottky diode doesn't flow in a trace between V_{IN} and R_{SENSE} as this could give an apparent higher measure of current than is actuality of trace resistance.

SC2008 ADJ pin

ADJ pin is high impedance input for voltage up to 1.35V, when left floating; PCB traces to this pin should be as short as possible to reduce noise. A 100nF capacitor (C) from ADJ pin to GND will reduce frequency modulation of output under these conditions. An additional series 10K Ω resistor (R) can also be used when driving ADJ pin from an external circuit. The resistor will provide filtering for low frequency noise and provide protection against high voltage transients.

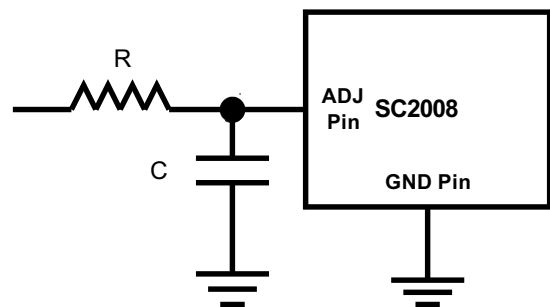

High voltage traces

Avoid high voltage traces close to ADJ pin, to reduce the risk of leakage current due to the board contamination. ADJ pin is soft-clamped for voltage above 1.35V to desensitize it to leakage that might raise ADJ pin voltage and cause excessive output current. However, GND ring placed around ADJ pin is recommended to minimize changes in output current under these conditions.

Package Information

TSOT-23-5

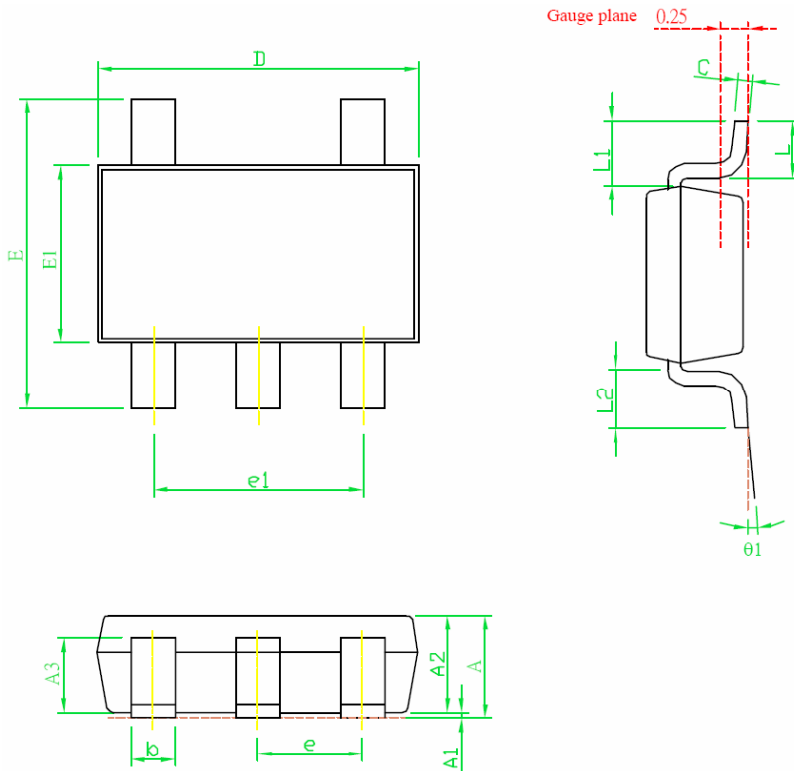

NOTE

1. PACKAGE BODY SIZES EXCLUDE MOLD FLASH PROTRUSIONS OR GATE BURRS
2. TOLERANCE ± 0.1000 mm (4 mil) UNLESS OTHERWISE SPECIFIED
3. COPLANARITY : 0.1000 mm
4. DIMENSION L IS MEASURED IN GAUGE PLANE

SYMBOLS	DIMENSIONS IN MILLIMETERS		
	MIN	NOM	MAX
A	---	---	1.00
A1	0.00	0.05	0.10
A2	0.84	0.87	0.90
A3	0.58	0.68	0.78
b	0.35	0.40	0.50
C	0.10	0.125	0.15
D	2.70	2.90	3.10
E1	1.40	1.60	1.80
e1	---	1.90(TYP)	---
E	2.60	2.80	3.00
e	---	0.95(TYP)	---
$\theta1$	1°	5°	9°
L	0.37	---	---
L1	---	0.6REF	---
L1-L2	---	---	0.12